

**Formula Drift Professional Drifting
2013 Pro-Am Affiliate and other Formula Drift Licensing
Series Supplemental Rules and Regulations**



Formula Drift Professional Drifting 2013 Pro-Am Affiliate and other Formula Drift Licensing Series Supplemental Rules and Regulations

INTRODUCTION

Entering its Tenth season, **Formula DRIFT** is recognized as the North American professional drifting championship series. As the first official series in North America, Formula DRIFT has taken competitive motorsports to the extreme attracting fans and car enthusiasts from all walks of life. This high-skilled, high-powered motor sport where drivers intentionally maneuver their cars into well executed, controlled sideways slides at high speeds through a marked course has dozens of professional drivers competing in all seven competitions this year.

The Formula Drift Pro Am Affiliate system is an extension to the Formula Drift Pro Championship. The FD Pro Am Affiliate system is made up of various regional point series that caters to the team/driver in transition from amateur to professional level. These Affiliate Series will feed the best up-and-coming drivers into the Formula Drift professional ranks.

Formula Drift Holdings, LLC

200 Pine Avenue, Suite 615

Long Beach, CA 90802

562-901-2600 (phone)

562-901-2651 (fax)

www.formuladrift.com (web)

Formula Drift Professional Drifting

2013 Pro-Am Affiliate and other Formula Drift Licensing Series Supplemental Rules and Regulations

The rules and regulations set forth in this document apply specifically to ProAM Affiliate series and other Formula Drift Approved licensing series vehicles and drivers.

These rules and regulations are exceptions from, or supplements to the Formula Drift PRO Rulebook. Unless otherwise noted all requirements of the Formula Drift Pro Rulebook are applicable to ProAM Affiliate series and other Formula Drift approved licensing series vehicles and drivers.

Section 4: SUSPENSION and BRAKES

The modifications to the subframe listed in 4.4 **will not be allowed** in ProAM vehicles or competitions

No additional mounting tabs may be added to relocate the suspension arm mounting points or the original mounting position.

Section 8: BODY INTERIOR and DRIVER's COMPARTMENT

8.13: Fire SUPPRESSION SYSTEM has been changed to the following:

8.13 FIRE SUPPRESSION SYSTEM

All cars must have at least a five (5) lb. minimum capacity fire extinguisher mounted in the driver's compartment within reach of the driver when he/she is in the normal seated position. The mounting bracket must be a quick-release type. Fire extinguishers must be current and inspection and/or recharge requirements cannot be expired.

The head of the fire extinguisher must be made of metal.

Acceptable extinguishants are Halon 1211, Halon 1301, Underwriters Laboratory 10BC rated Potassium Bicarbonate (Purple K), Underwriters Laboratory 1A10BC Ammonium Phosphate/Barium Sulfate, or Monnex.

On-Board Fire Suppression systems are strongly recommended. An on-board fire system must conform to FIA Technical List #16, or meet SFI spec 17.1.

On board systems are required to have at least one (1) nozzle in the engine compartment, and one (1) nozzle in the driver's compartment. In addition, one (1) nozzle is required in the fuel tank compartment (trunk) if no Fuel Cell is used.

Section 9: Tires

Are intended only for Formula Drift Pro Events and Drivers

Formula Drift Professional Drifting 2013 Pro-Am Affiliate and other Formula Drift Licensing Series Supplemental Rules and Regulations

Suggested Roll Cage layout: (NO tubes are allowed from the strut bar to firewall)

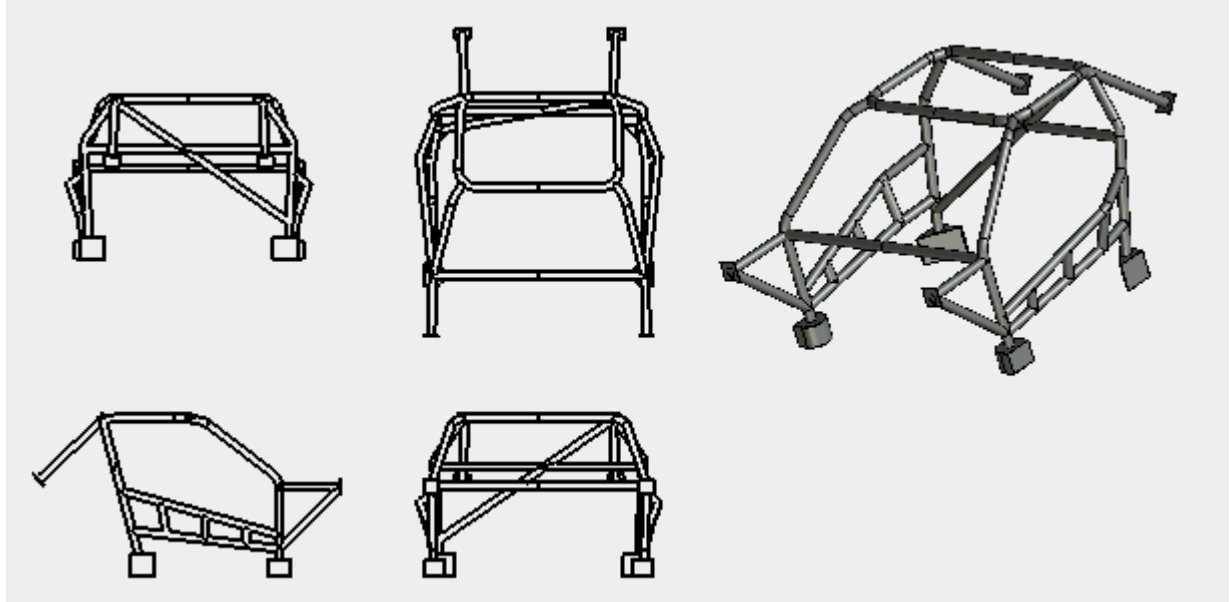
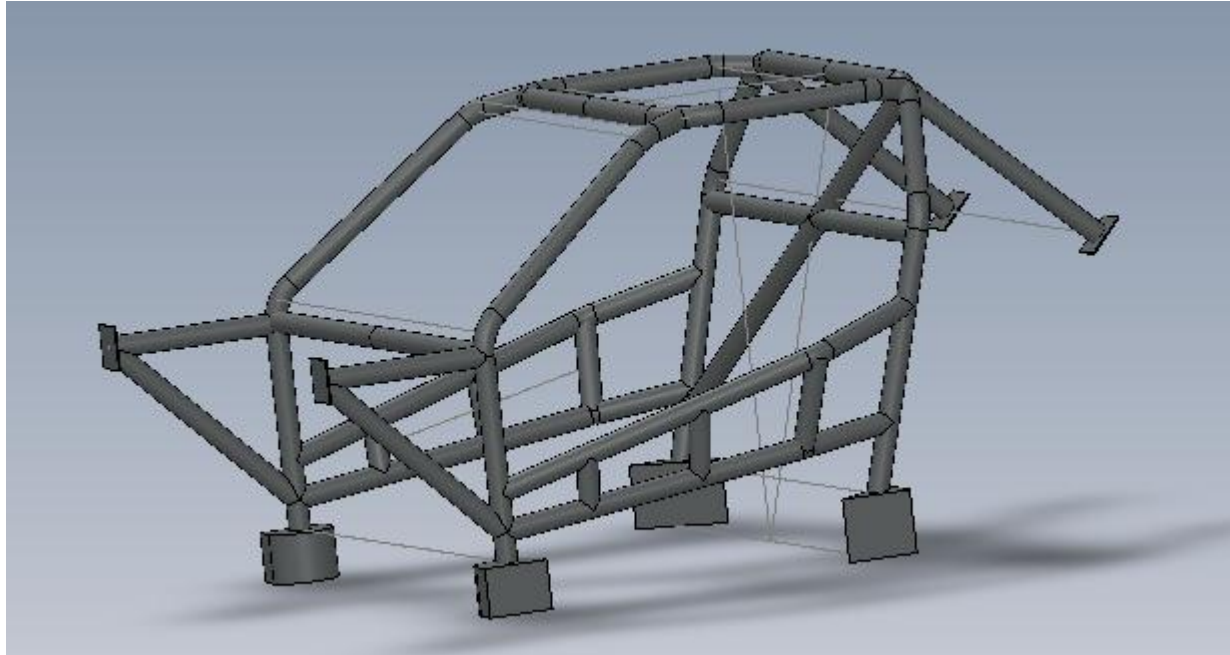

Formula Drift Professional Drifting 2013 Pro-Am Affiliate and other Formula Drift Licensing Series Supplemental Rules and Regulations

Record of Revisions
8/29/2012

Release	Current Version	Release Date	Notes
2013 FD Pro-Am Drifting Rules & Regulations	1.0	8/29/2012	Production Release